

MCD Diamond Tools

Mirror machining & Customized

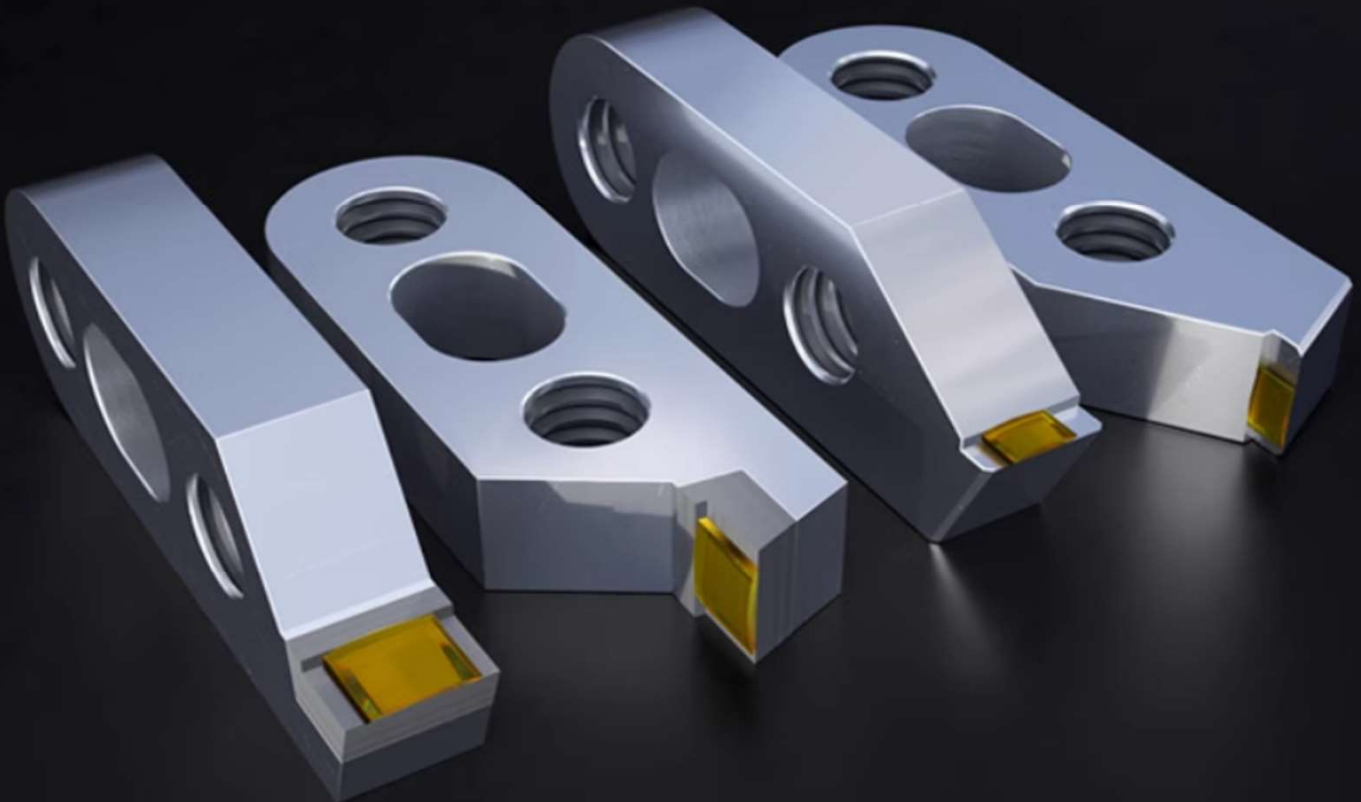

Company Profile

ToolingBox (Beijing) Industrial Technology Co.,Ltd is a Chinese professional manufacturer for cutting tools. We supply solid&brazed CBN tools, Tipped PCD inserts and tools, carbide inserts and tools for woodworking and metalworking industries.

With over a decade of dedicated expertise, our company specializes in the research, development, production, promotion, and technical service of tungsten carbide cutting tools. Our product range includes woodworking carbide reversible knives, molding knives, circular cutters, oscillating knives, carbide thin razor blades, carbide scrapers, and more. These products find extensive applications in wood processing, paper printing, film and fiber industries, electronic battery cutting, and various other sectors. Renowned for our outstanding product quality and prompt deliveries, we have garnered recognition from numerous customers, leading to a significant domestic market share and exports to countries and regions, including Europe, the United States, Russia ,Mid east ,India and Southeast Asia.

Our company possesses a comprehensive set of standardized testing equipment and processes to ensure product quality. We are supported by a professional team specializing in production, technology, and sales, capable of addressing various customer-related issues. With over 100 CNC grinding machines, end mills, surface grinders, and a variety of imported inspection devices, we stand as one of the industry's largest, highest-output, most diverse, and fully-equipped enterprises in China.

We adhere to the business philosophy of "integrity in operation, superior quality, and customer-first", continuously enhancing our corporate image and product quality, reducing overall costs, shortening delivery times, and consistently improving customer satisfaction.

ToolingBox, Professional makes values!





Raw material production



Raw material inspection



Flat grinding



CNC cutting edge



CNC grinding machine



Cleaning



Inspection of the first



Inspection of the second

Page	05	MCD Introduction
Page	06	MCD Polishing/ Engraving Tools
Page	07	MCD Endmills/Chamfer Tools
Page	08	MCD Outer Arc Milling Cutter
Page	09	MCD Internal Arc Milling/Plane making Tools
Page	10	MCD Rolling/ Trimming Cutter
Page	11	MCD Turning Inserts
Page	12	Checklist for Customized MCD tools
Page	13	Application

What is MCD?

MCD stands for Monocrystalline Diamond. The other name of MCD is SCD, which stands for Single Crystal Diamond. MCD is a single synthetic diamond that has a yellow like crystal.

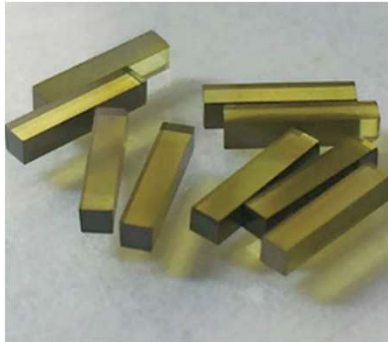

Properties of MCD?

Excellent thermal conductivity and good wear resistance & repeatability of chemical, physical and thermal characteristics.

Chemical and physical properties

Hardness	10,000kg/mm ²
Density	3.51 g/cm ³
Young's modulus	1.22 Gpa
Index of refraction at 650 nm	2.41
Thermal conductivity x	1200 W/mK
Optical transmissivity at 650 nm	65%
Wear resistance	up to 15% higher than natural diamond
Complete impurity absorption	450-500 nm

what's the advantage of MCD tools?

- High hardness and wear resistance
- High efficiency and low cost
- High surface finish can be obtained on your workpiece
- Topped octahedron shapes, rhombic-dodecahedron shape or simply plate like crystals.

Mono-crystal diamond tools are often used for machining high - precision parts with mirror finish. The mono-crystal diamond tools can achieve excellent cutting edge by grinding .The surface finish can reach 0.025 micron or higher.

ToolingBox can offer 100 orientation (4 point diamond) with dimensions available are all sizes up to 8mm x 8 mm x 1.60-1.70 mm.

MCD diamond mirror polishing tools

- High grade MCD diamond materials to meet mirror finishing machining effect for acrylic industry.
- Precision machining, high wear resistance, long service life.
- Excellent price/performance ratio, great value for money

Application	Mirror Polishing
Suitable Materials	Acrylic, Glasses, Light guide plate
Tolerance	0.005-0.01mm

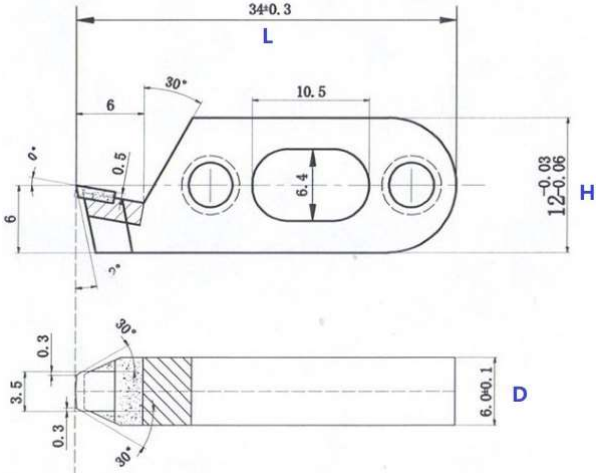

@Other size can be customized

MCD diamond Engraving tools

- High grade MCD materials and sharpened edges for engraving machining for non-ferrous metals, gold and silver jewelry and acrylic industry.
- Can process difficult-to-process workpieces.
- Precision machining, high wear resistance, long service life.
- Can be renewed many times, Excellent price/performance ratio, great value for money

Application	Engraving Machining
Suitable Materials	Non-ferrous metals, Gold and Silver Jewelry, Acrylic
Tolerance	0.005-0.01mm

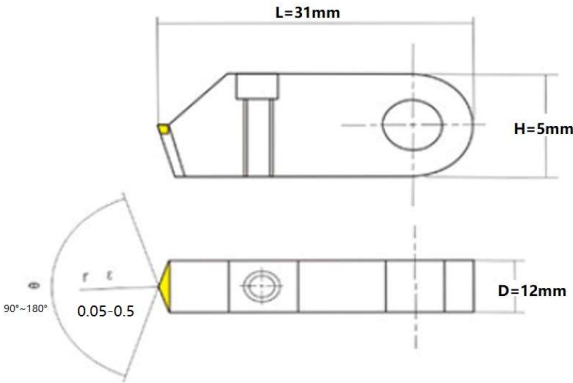
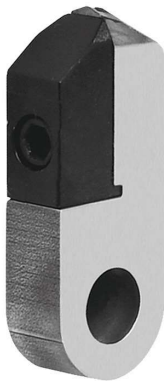

@Other size can be customized

MCD Endmills for mirror milling



- High grade MCD materials and sharpened edges for end milling and side milling for Cast Aluminum, Aluminum-Silicon Alloy, Aluminum, PVC and Acrylic.
- Can process difficult-to-process workpieces
- High wear resistance, long service life.
- Excellent price/performance ratio, great value for money
- All sizes can be customized

Application	End milling or side milling for mirror machining
Suitable Materials	Cast Aluminum, Aluminum-Silicon Alloy, Aluminum, PVC, Acrylic
Tolerance	0.005-0.01mm

MCD Chamfering tools

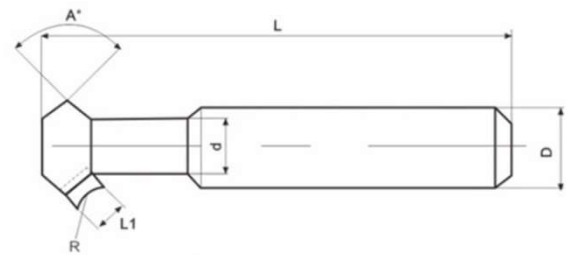

- High grade MCD materials and sharpened edges for chamfering machining for Cast Aluminum, Aluminum-Silicon Alloy, Aluminum, PVC and Acrylic.
- Can process difficult-to-process workpieces
- High wear resistance, long service life.
- Excellent price/performance ratio, great value for money
- Normal shank diameter is D6mm, other sizes can be customized

Application	Chamfering for mirror machining
Suitable Materials	Cast Aluminum, Aluminum-Silicon Alloy, Aluminum, PVC, Acrylic
Tolerance	0.005-0.01mm

MCD Outer Arc Milling Cutter



- High grade MCD materials and sharped edges for outer arc milling for Cast Aluminum, Aluminum-Silicon Alloy, Aluminum, PVC and Acrylic.
- Can process difficult-to-process workpieces
- High wear resistance, long service life.
- Excellent price/performance ratio, great value for money
- All sizes can be customized

Application	Outer Arc Milling for mirror machining
Suitable Materials	Cast Aluminum, Aluminum-Silicon Alloy, Aluminum, PVC, Acrylic
Tolerance	0.005-0.01mm

MCD External Arc Milling Cutter

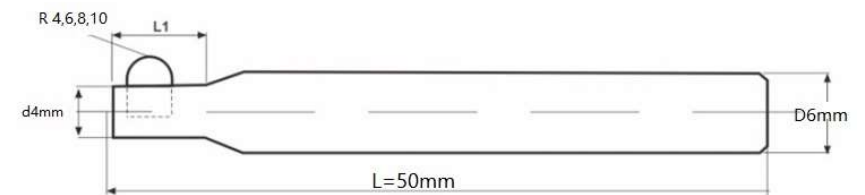
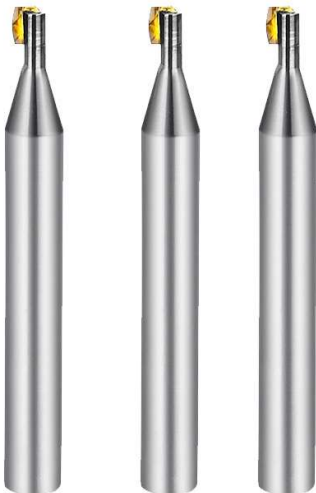

- High grade MCD materials and sharped edges for external arc milling for Cast Aluminum, Aluminum-Silicon Alloy, Aluminum, PVC and Acrylic.
- Can process difficult-to-process workpieces
- High wear resistance, long service life.
- Excellent price/performance ratio, great value for money
- Normal shank diameter is D6mm, other sizes can be customized

Application	for external arc milling for mirror machining
Suitable Materials	Cast Aluminum, Aluminum-Silicon Alloy, Aluminum, PVC, Acrylic
Tolerance	0.005-0.01mm

MCD Internal Arc Milling Cutter

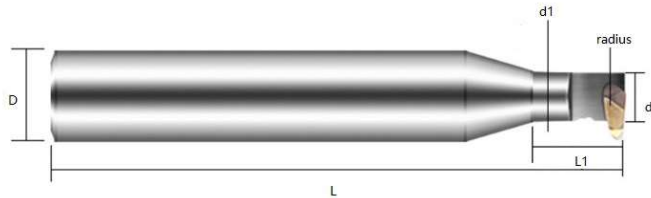

- High grade MCD materials and sharpened edges for MCD Internal Arc Milling Cutter for Cast Aluminum, Aluminum-Silicon Alloy, Aluminum, PVC and Acrylic.
- Can process difficult-to-process workpieces
- High wear resistance, long service life.
- Excellent price/performance ratio, great value for money
- All sizes can be customized

Application	MCD Internal Arc Milling Cutter For mirror machining
Suitable Materials	Cast Aluminum, Aluminum-Silicon Alloy, Aluminum, PVC, Acrylic
Tolerance	0.005-0.01mm

MCD Plane Marking tools

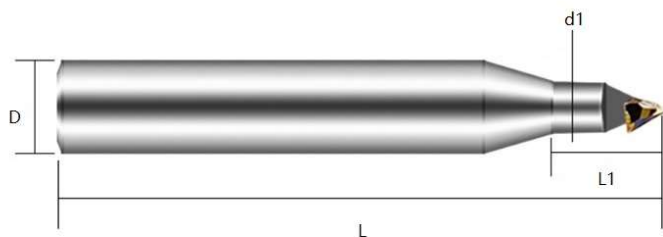

- High grade MCD materials and sharpened edges for Plane Marking Line application for Cast Aluminum, Aluminum-Silicon Alloy, Aluminum, PVC and Acrylic.
- Can process difficult-to-process workpieces
- High wear resistance, long service life.
- Excellent price/performance ratio, great value for money
- Normal shank diameter is D6mm, other sizes can be customized

Application	Plane Marking Line
Suitable Materials	Cast Aluminum, Aluminum-Silicon Alloy, Aluminum, PVC, Acrylic
Tolerance	0.005-0.01mm

MCD Rolling Cutter



- High grade MCD materials for rolling machining for Cast Aluminum, Aluminum-Silicon Alloy, Aluminum, Acrylic and glasses polishing
- Can process difficult-to-process workpieces
- High wear resistance, long service life.
- Excellent price/performance ratio, great value for money
- All sizes can be customized

Application	Rolling for mirror machining
Suitable Materials	Cast Aluminum, Aluminum-Silicon Alloy, Aluminum, PVC, Acrylic and glasses mirror polishing
Tolerance	0.005-0.01mm

MCD Trimming cutter



- High grade MCD materials and sharpened edges for trimming Acrylic, PVC and wood.
- Can process difficult-to-process workpieces
- High wear resistance, long service life.
- Excellent price/performance ratio, great value for money
- All sizes can be customized

Application	Trimming machining
Suitable Materials	Acrylic, PVC and wood
Tolerance	0.005-0.01mm

MCD Turning Inserts

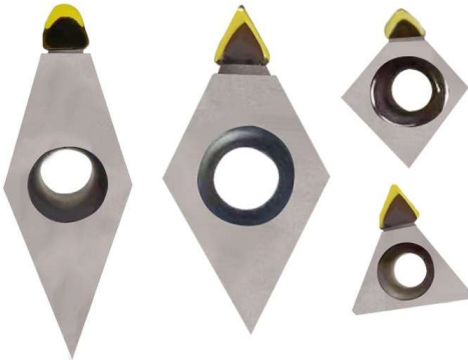

- High grade MCD materials for rolling machining for Cast Aluminum, Aluminum-Silicon Alloy, Aluminum, Acrylic and glasses polishing
- Can process difficult-to-process workpieces
- High wear resistance, long service life.
- Excellent price/performance ratio, great value for money
- All sizes can be customized

Application	Rolling for mirror machining
Suitable Materials	Cast Aluminum, Aluminum-Silicon Alloy, Aluminum, PVC, Acrylic and glasses mirror polishing
Tolerance	0.005-0.01mm



Trimming Machine



Engraving Machine



Router Milling Machine

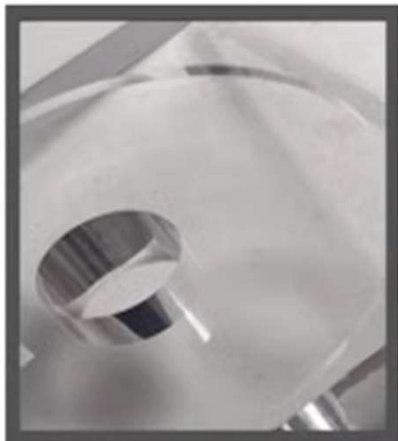

Acrylic



PVC



ABS Plate



Density Board



PP Plate

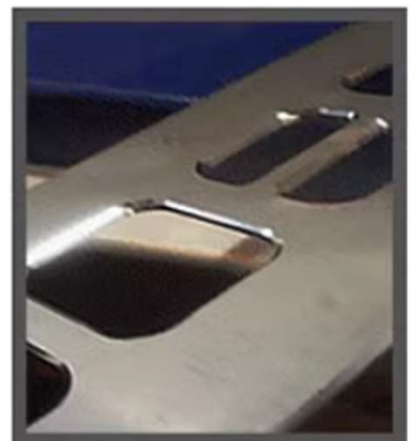

Al alloy



ToolingBox[®]

ToolingBox(Beijing) Industrial Technology Co.,Ltd
Rm503, Building A, Langting Plaza, No.8 Chaoyang
Road, Chaoyang District, 100024,
Beijing P.R of China

Phone: +86 10 5290 2905
Email: sales@toolingbox.com
Company Web: www.toolingbox.com